



WATER-OIL SEPARATOR WOSm

DESCRIPTION

WOSm water oil separators have been specifically developed to separate lubricant oil from condensate generated in compressed air systems. Due to patented technology regular service can be done in 30 seconds without any cleaning. Separation begins in “*cyclonic depressurization chamber*” and continues in “*filter cartridge*”. When the “*filter cartridge*” is fully saturated you just simply unscrew complete cartridge and replace it with new one. All oil from condensate stays in cartridge and all remaining condensate can be drained to sewage while complying with the environment laws. Worn cartridge can be sealed with plastic cover and disposed according to local directives and laws.



APPLICATIONS

- Compressed air systems
- Suitable for installation Inside compressors

TECHNICAL SPECIFICATION

Operating temperature	1,5 - 45 °C (max. 65°C) ^[1]	35 - 113 °F (max. 149 °F) ^[1]
Operating media	Condensate (air, water, oil); Non-agressive; Not suitable for emulsion	
Residual oil content	Less than 20ppm	

Service interval	When first of the following parameters appears:	
	-	4000 operating hours of compressor ⁽²⁾
	-	12 months regardless compressor operating hours
	-	All white polypropylene filling becomes yellow (adsorbed oil). During operation colored area (adsorbed oil) spreads from top of the cartridge to the bottom.

^[1]Max. operating temperature is 65°C, but when temperature is over 45°C, performance may decrease.
⁽²⁾At compressor oil carryover 2,5mg/m³. Lower/higher oil carry over means proportionally longer/shorter lifetime (e.g. if oil carryover is 5mg/m³ lifetime reduces to 2000 operating hours).

MATERIALS

Housing material	Pa6 30% Glass fiber, Aluminium
Transparent part	Acryl
Fittings	Steel, anodized
Sealing	NBR
Filter material	PP (polypropylene), Active carbon
Bonding	Polyurethane



SIZES

	Cold climate zone 15°C 60%RH	Mild climate zone 25°C 60%RH	Hot climate zone 40°C 100%RH	
WOSm1	740	650	370	Max oil adsorption[g]
	1,23/43,05	1,08/37,8	0,62/21,9	Max FAD [Nm ³ /min]/[scfm]
	0,57	0,90	1,91	Max condensate flow [l/h] ⁽³⁾
WOSm2	1520	1340	770	Max oil adsorption[g]
	2,54/88,9	2,23/78,05	1,28/45,2	Max FAD [Nm ³ /min]/[scfm]
	1,19	1,87	3,96	Max condensate flow[l/h] ⁽³⁾

⁽³⁾Max condensate volume per condensate drain single discharge is 0,125 ltr.
Minimum settle/resting time between two consecutive discharges is 30 s.

	WOSm1	WOSm2
Nr. of inlet connections	1	1
Nr. of outlet connection	1	1
Connection type	Push-in fitting for hose 8mm	
DIMENSIONS		
A [mm]	483	816
B [mm]		106
C [mm]		80
D [mm]	335	670
E [mm]		50

MAINTENANCE

It is recommended, that you do a check once per week to evaluate filter cartridge saturation. Filter cartridge must be replaced according to above mentioned specifications.

Water quality can also be checked with "oil indicating test paper". For test set please contact us or your local distributor.

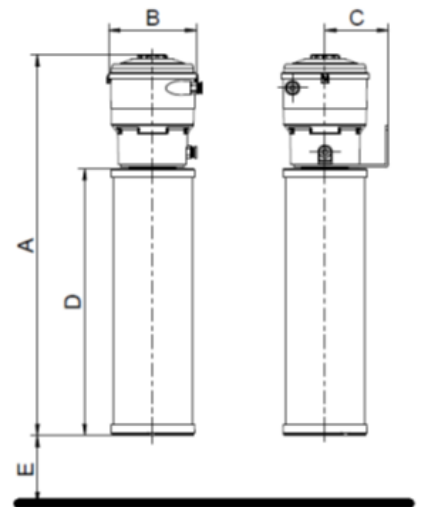

All WOSm products are DIBt approved and listed with serial number Z-83.5-31.